

Swann Technical Support

All Countries E-mail: tech@swann.com.au

Telephone Helpdesk

UNITED STATES toll free

877-274-3695

(Sun-Thurs, 2pm-10.30pm PST)

800-627-2799

(Mon-Fri, 9am-1pm PST)

USA Exchange & Repairs

562-777-2551

(Mon-Fri, 9am-5pm PST)

AUSTRALIA toll free

1300 13 8324

(Mon-Fri, 9am-5.30pm Aus EST)

International

+61 3 8412 4610

(Mon-Fri, 9am-5.30pm Aus EST)

See <http://www.worldtimeserver.com> for information on different time zones and the time in Melbourne Australia compare to your local time.

Warranty Information

Swann Communications warrants this product against defects in workmanship and material for a period of one (1) year from its original purchase date. You must present your receipt as proof of date of purchase for warranty validation. Any unit which proves defective during the stated period will be repaired without charge for parts or labour or replaced at the sole discretion of Swann. The repair or replacement will be warranted for either ninety days or the remainder of the original one year warranty period, whichever is longer. The end user is responsible for all freight charges incurred to send the product to Swann's repair centres. The end user is responsible for all shipping costs incurred when shipping from and to any country other than the country of origin. The warranty does not cover any incidental, accidental or consequential damages arising from the use of or the inability to use this product. Any costs associated with the fitting or removal of this product by a tradesman or other person or any other costs associated with its use are the responsibility of the end user. This warranty applies to the original purchaser of the product only and is not transferrable to any third party.

Unauthorised end user or third party modifications to any component or evidence of misuse or abuse of the device will render all warranties void.



www.swannsecurity.com



Night Hawk

Extra Wireless Outdoor Camera

With 4 Channel Switching



Swann Helpdesk
Has the answers



If this device does not work when you first plug it in, do not take it back to the store.

✓ Contact the Swann Helpdesk using our fast e-mail service tech@swann.com.au or call us on one of the Toll-Free numbers shown on the back cover of this booklet.

✓ Most problems can be quickly and easily fixed with a simple e-mail or a quick chat with one of our friendly technical staff. (Toll-Free available in the US and Australia only)

Note: Wireless Networks (WiFi) may interfere with and/or experience interference caused by the transmitter in this unit. Changing the receiver to another channel/frequency or setting the Wireless Network (i.e. Wireless Access Point) to a frequency further away from the camera's set frequency can alleviate this problem. Consult the documentation of your Wireless LAN device for information on how to change the transmission frequency. These cameras work with most wireless camera receivers that support 2414MHz, 2432MHz,

Installation Guide

Index

Introduction	2
This package comes with...	2
Installing your Nighthawk Camera	3
Camera Features	4
Important Information about your Nighthawk Camera	5
Troubleshooting, Hints & Tips	6
Technical Specifications	7
Help Desk / Support Details	Back Cover
Warranty Information	Back Cover

Introduction

The Swann Nighthawk Camera incorporates the latest in advanced technology. We feel confident that you will be pleased with the quality and features of this product.

The Swann Nighthawk Camera allows you to transmit pictures with ease. As the radio waves it uses have a frequency of 2.4GHz, they can be received within a radius of up to 328ft/100m in open line of sight. The Nighthawk Camera comes with 2 power sources (9V battery and mains adaptor) so that you have the option of using different power methods for different locations and conditions, to ensure that you have the best options for your situation.

Please note: The Swann Nighthawk Camera broadcasts video in the public domain. The video signal is not encrypted and could potentially be viewed by anyone with a similar 2.4GHz receiver unit. Please keep this in mind when positioning and using any wireless camera equipment.

This Package Comes With ...

- 1 x 2.4GHz Wireless Nighthawk Camera / Built-in Transmitter with Stand
- 1 x Mains Power Adaptor (8V for use with Camera)
- 1 x 9V Battery Snap (battery not included)
- This Instruction Sheet

If any of these items are missing, please contact your retailer.

FCC NOTICE

This device complies with Part 15 of FCC Rules. Operation is subject to the following conditions:
(1) This device may not cause harmful interference, and
(2) this device must accept any interference received, including interference that may cause undesired operation

Technical Specifications

Channels:	1-2414, 2-2432, 3-2450 & 4-2468MHz
RF Output Power:	CE, FCC & C-tick compliant
Operating Power:	8V DC 200mA
Power Consumption:	100mA
Size:	54 x 43mm (2 ¹ / ₈ " x 1 ⁷ / ₁₀ ")
Antenna:	Omni-directional
Transmitting Range:	Up to 328ft (100M) line of sight
Weight:	7 ³ / ₄ oz (220 grams)
Operating Temperature:	32° - 122°F ~ (0° - 50°C)
Sensor:	1/3"(8.5mm) Colour CMOS
Horizontal Resolution:	380 TV lines
Auto Electronic Exposure:	1/60 - 1/15000 sec.
Minimum Illumination:	1 Lux@ f1.2
Signal to Noise Ratio:	>48dB
Board Lens:	7 ¹ / ₃₂ " (5.6mm)
View Angle:	60 degrees
Video System:	NTSC 60Hz USA & Canada ~ PAL 50Hz AU, UK & EU
Automatic Exposure / Gain / White balance.	

FCC Notice

We, Swann Communications of 10612 Shoemaker Avenue, Bldg A, Santa Fe Springs, CA 90670 USA, declare under our sole responsibility that the Nighthawk Camera:

SW-P-WOCEX

To which this declaration relates:

This equipment has been tested and found to comply with the limits for a Class B digital device, pursuant to part 15 of the FCC Rules. These limits are designed to provide reasonable protection against harmful interference in a residential installation. This equipment generates, uses, and can radiate radio frequency energy and, if not installed and used in accordance with the instructions, may cause harmful interference to radio communication. However, there is no guarantee that interference will not occur in a particular installation. If this equipment does cause harmful interference to radio or television reception, which can be determined by turning the equipment off and on, the user is encouraged to try to correct the interference by one or more of the following measures:

- Reorient or relocate the receiving antenna.
- Increase the separation between the equipment and receiver.
- Connect the equipment into an outlet on a circuit different from that to which the receiver is connected.
- Consult the dealer or an experienced radio/TV technician for help.

CE Notice

This product complies with standards including Low Voltage Device Directive 73/23/EEC; EMC Directive 89/336/EEC and R&TTE Directive 1999/5/EC. It passed the subject tests by the authority concerned and is authorized to bear CE mark.

Troubleshooting your Night Hawk Camera

Poor Picture: Realign antennas until image quality improves, slightly adjust the position of the Camera or Receiver. Change the location of the Camera, or use a different height or angle to see if the image improves. In some cases interference may be caused by another device on a similar frequency to the channel you are using.

Lines only - no clear picture: Check to confirm there is no microwave oven or other 2.4GHz equipment operating close by ie; Cordless Telephones, Wireless Baby Monitors, Wireless LAN equipment etc . Make sure the Receiver is on the correct channel.

Picture ghosting or interference: Some home appliances such as Wireless LANs, 2.4GHz portable telephones and Microwave ovens operate on or near the 2.4GHz frequency. If you receive interference from such an appliance, try moving the Camera or Receiver to location further away from the appliance or in the event of interference from a Wireless LAN device, try changing the Wireless LAN to a different channel to improve the signal quality.

No picture: check the receiver to confirm it is turned ON and make sure the AV connection of the Receiver is not plugged into the Audio Out socket. Make sure the Receiver is on the correct channel. Check to ensure the camera is plugged in and has power. Check that the channel on the receiver is the set to Channel x.

Red haze over picture: In some cases where the sun shines into the front of the camera a faint red glow can be seen. Move the camera to a shaded location, or fit a hood to stop sunlight entering the camera lens directly.

Foreground is dark while background is too bright: If the camera is looking from a dark area towards a light area in some cases the automatic exposure can find it difficult to balance the image correctly. Change the location of the camera so that the point of greatest interest has the largest area of the image.(If you want to see the bright area, move the camera so that almost all of the screen shows this area. If you want to see the darker area, move the camera so that most of the image shows this area.

Installing your Night Hawk Camera

The Wireless Outdoor Camera can be switched to four frequencies to assist in avoiding interference. To set or change frequencies, take off the front cover by unscrewing it anti-clockwise fig.(1). Please see the below illustration fig.(2) for frequency settings. To change the frequency/channel on the receiver, press the appropriate button to cycle through the channels.

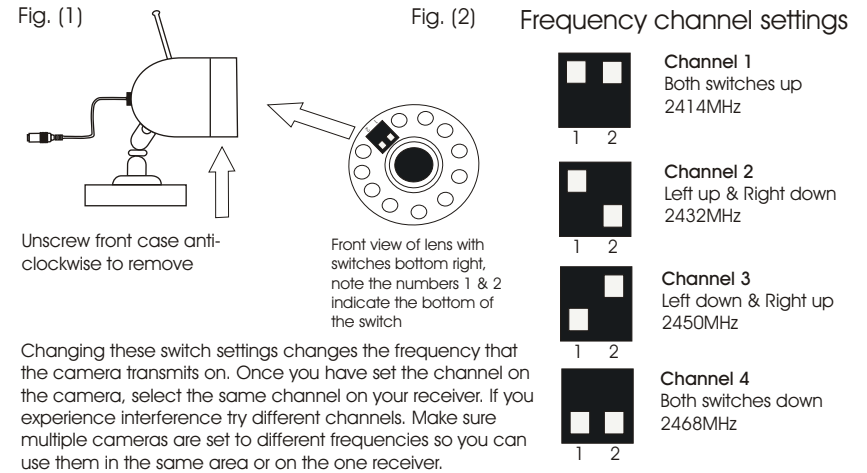

- 1) Connect both the Nighthawk Camera and the Receiver to their respective power adaptors.
- 2) Connect the Receiver to the equipment you wish to view the camera on (monitor, TV, VCR etc) using the supplied RCA cable.
- 3) **After connecting both the Camera and the Receiver make sure the receiver is switched to the same channel as the Nighthawk Camera.**
Obtain the best picture by adjusting the position of the Nighthawk Camera and Receiver unit to suit. Try slightly different locations of either unit for optimum results.
- 4) If you are mounting the camera to a ceiling or eave, unscrew the camera stand from the camera body and carefully screw it into position on the top side of the camera using the two holes that are provided to ensure the picture is not upside down.
- 5) Align the antenna of the receiver toward the antenna of the Nighthawk Camera and test the reception quality.

Camera Features

To take advantage of any unused channels on your receiver you can purchase additional Night Hawk Extra Cameras, or a MicroCam IV Color Indoor Camera (product code SW-P-MC4) can be used. The MicroCam IV Camera has similar DIP switches to the Nighthawk Camera, which allow the use of any of the other available channels on your receiver.

Camera Power Adaptor (8V)

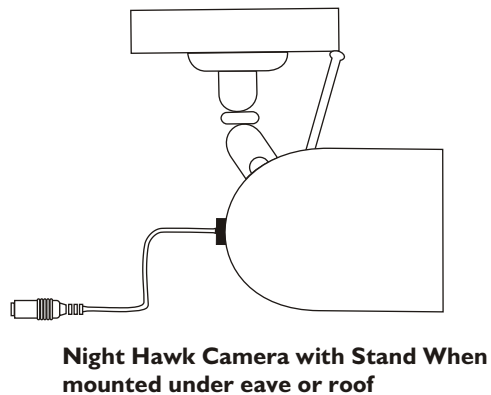
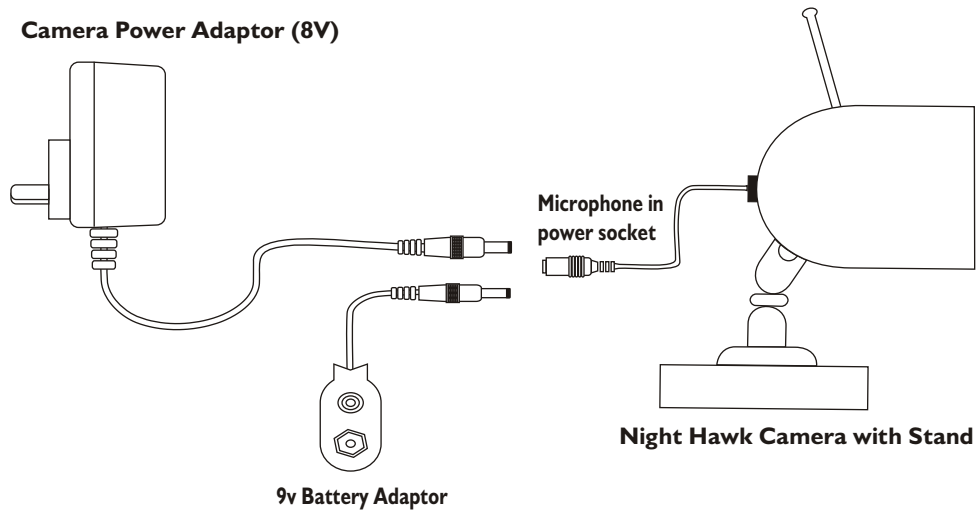

Night Hawk Camera with Stand When mounted under eave or roof

IMPORTANT: Due to the power consumption requirements of this product, we highly recommend the use of a 9 volt battery only for short term portable use.

Important Information about your Night Hawk Camera

- Best Results are achieved where there is a clear "line of sight" between the Nighthawk Camera transmitter and Receiver.
- Try to avoid obstacles such as trees, walls, cars, trucks and buildings when maximum range is required.
- Interference from certain electronic equipment or the moving human body can also affect the range obtainable.
- Please test all devices before final installation because transmission quality can often be improved by moving the components slightly.
- Turn off the transmitter and receiver if the system is not in use.
- Do not touch the antennas when the system is switched on.
- Do not place the receiver behind a monitor or TV.
- To avoid the risk of damage to Nighthawk Camera, use only the supplied power adaptors.
- Don't place above or near a heat source which may cause the equipment to overheat.
- Microwave ovens can cause interference and diminish the quality of the signal if the Nighthawk Camera or Receiver are located close by.
- Beware of humid locations. Water droplets or spray may damage the units. If condensation does occur, do not use until the equipment has dried out.
- Never paint or attach metallic labels or stickers of any kind.
- Do not use two Nighthawk Camera systems operating at the same time in the same area using the same channel. This will result in picture interference. Switch one camera to one of the unoccupied channels using the DIP switches.
- Do not cut the DC power cable of the Nighthawk Camera to fit with another power source. This may result in damage to the Nighthawk Camera & any unauthorised modifications will void your warranty.